



ÚŘAD PRO CIVILNÍ LETECTVÍ  
ČESKÁ REPUBLIKA  
**Sekce technická**  
*letišťe Ruzyně, 160 08 Praha 6*  
*tel: 233320922, fax: 220562270*

## PŘÍKAZ K ZACHOVÁNÍ LETOVÉ ZPŮSOBILOSTI

**Číslo: A- 2005-003**

Datum účinnosti: **ihned po obdržení**

**Diamond Aircraft Industries GmbH**  
model DA 42

---

Tento PZZ je vydáván pro výrobek transferovaný pod působnost EASA

Na základě rozhodnutí EASA je následující Příkaz k zachování letové způsobilosti závazný pro všechny výrobky provozované v EU na které se daný PZZ vztahuje.

Provedení PZZ, který se vztahuje podle typu a výrobního čísla na výrobek je pro provozovatele/vlastníka letadla zapsaného do leteckého rejstříku závazné. Neprovedením PZZ ve stanoveném termínu dojde ke ztrátě letové způsobilosti výrobku.

---

*Poznámky:*

- *Provedení tohoto PZZ musí být zapsáno do provozní dokumentace letadla.*
- *Případné dotazy týkající se tohoto PZZ adresujte na ÚCL sekce technická.*
- *Pokud to vyžaduje povaha tohoto PZZ, musí být zapracován do příslušné části dokumentace pro obsluhu, údržbu a opravy letadla.*

**Aeroplane DA 42**

Exchange of the Wing Stub Safety Walks,  
Revision of the Airplane Flight Manual  
Single Engine Rate of Climb/Descent

Supersedes AD A-2005-001R1

page 1 of 2

1. Applicability: DA 42, EASA TCDS.A.005  
Diamond Aircraft Industries GmbH (DAI), Austria, DOA No. EASA 21J.052  
  
S/N 42.004 and up
2. Subject: Exchange of the wing stub safety walks  
Revision of the DA 42 AFM "One Engine Inoperative Climb/Descent Diagram"  
  
AD A-2005-003 (EASA Approval No. 2005-6381) supersedes AD A-2005-001R1 (EASA Approval No. 2005-6181).
3. Reason: It has been determined that the surface roughness of the wing stub safety walks Series 300, gray color (equals sandpaper grid 40), installed during production on some aeroplane S/Ns, adversely affects the aircraft single engine climb performance.  
  
AFM published twin engine climb performance is not affected by this AD.
4. Actions: Perform actions as applicable in accordance with the compliance times listed in paragraph 5.:
- A) For S/N 42.004 through 42.035, and 42.037 perform following actions:
- i) Assure that AFM TR-MÄM-42-103, distributed with DAI MSB42-005, is inserted into AFM Doc. 7.01.05-E, rev. 2 or earlier revision.  
TR-MÄM-42-103 has to remain in the AFM until action A)ii and A)iii) have been carried out.  
  
Previous compliance with AD A-2005-001 or AD A-2005-001R1 satisfies the requirements of this paragraph.
  - ii) Exchange the wing stub safety walks in accordance with DAI MSB-42-006/1, issue date September 20, 2005, paragraph 1.8, Action 2 a) to b).
  - iii) Remove obsolete TR pages from the AFM and insert TR-MÄM-42-111/a in accordance with DAI MSB-42-006/1, issue date September 20, 2005, paragraph 1.8, Action 2 c) to e).

**Aeroplane DA 42**

Exchange of the Wing Stub Safety Walks,  
Revision of the Airplane Flight Manual  
Single Engine Rate of Climb/Descent

Supersedes AD A-2005-001R1

page 2 of 2

B) For S/N 42.036, 42.038 through 42.064, 42.107, 42.109, 42.110, and 42.177 perform following actions:

- i) Assure that AFM TR-MÄM-42-103, distributed with DAI MSB42-005, is inserted into AFM Doc. 7.01.05-E, rev. 2 or earlier revision.  
TR-MÄM-42-103 has to remain in the AFM until action B)ii) has been carried out.

Previous compliance with AD A-2005-001 or AD A-2005-001R1 satisfies also the requirements of this paragraph.

- ii) Remove obsolete TR pages from the AFM and insert TR-MÄM-42-111/a in accordance with DAI MSB-42-006/1, issue date September 20, 2005, paragraph 1.8, Action 3 a) to c).

C) For S/N 42.004 and up:

- i) No wing stub safety walks Series 300 (equals sandpaper grid 40), gray color, P/N D60-1127-10-51 (no revision letter attached) may be installed as spare part on the DA42.  
Only DAI released safety walk P/Ns with a surface roughness equal to or finer than sandpaper grid 100 are approved for installation as spare parts.
- ii) AFM-TR-MÄM-42-111/a, or a later TR revision, or an AFM revision containing the information of TR-MÄM-42-111/a, must remain part of the DA42 AFM, Doc. No. 7.01.05-E.

5. Compliance: Compliance with A)i), B)i), C)i) is required immediately upon receipt of AD A-2005-003.

Compliance with A)ii), A)iii), B)ii), C)ii) is required at the next scheduled inspection, latest December 31, 2005.

6. Accomplishment: The required actions have to be accomplished and documented either by the manufacturer, or a licensed/qualified person/organisation in accordance with national regulations.

7. Effective Date: AD A-2005-003 becomes effective upon receipt.

This AD was approved by EASA under reference No.2005-6381

# MANDATORY SERVICE BULLETIN

## NO. MSB-42-006/1

SUPERSEDES MSB-42-005

SUPERSEDES MSB-42-006

### **I TECHNICAL DETAILS**

#### **I.1 Category**

Mandatory

#### **I.2 Airplanes affected**

Type: DA 42

Serial Numbers: 42.004 through 42.035, 42.037 (Action 1 & Action 2)

42.036, 42.038 through 42.064,  
42.107, 42.109, 42.110, 42.177 (Action 3)

#### **I.3 Time of Compliance**

Action 1  
Upon receiving of this Service Bulletin

Action 2 and 3  
During next scheduled inspection, not later than 31-Dec-2005

#### **I.4 Subject**

Exchange of the Safety Walk on the Wing Stubs.

Issuance of a Temporary Revision to the AFM to amend the one engine inoperative climb/descent performance data.

#### **I.5 Reason**

It has been found that the airplane fails to reach the one engine inoperative climb/descent data shown in the Airplane Flight Manual. In this context it has been determined, that the Safety Walk - 300 Series, color grey –coarse surface, has an adverse influence to the rate of climb – single engine operation. Replacement is necessary. In addition to that a Temporary Revision to the Airplane Flight Manual is

issued in which the one engine inoperative performance values are reduced to a conservative level.

The normal climb rate (both engines operative) is not affected.

## **I.6 Concurrent Documents**

none

## **I.7 Approval**

The technical information or instructions contained in this document relate to the Design Change Advisory No. MÄM 42-107, which has been approved under the authority of EASA Design Organization Approval No. EASA.21J.052 and MÄM 42-111/b which has been approved by EASA.

The technical content of this document has been approved und the authority of DOA No. EASA.21J.052.

## **I.8 Accomplishment/Instructions**

Action 1:

- a Check that MSB 42-005 is complied with.

Action 2:

- a Remove Safety Walk Series 300, color grey – coarse surface (surface roughness equal to sandpaper with grid 40). For replacement refer to AMM, Chapter 11-00.
- b Install new Safety Walk D60-1127-10-51 Rev. “a” or later issue (surface roughness equal or finer than sandpaper grid 100) according to drawing D60-1120-20-00SB, latest effective revision. For replacement refer to AMM, Chapter 11-00.
- c Remove AFM-TR-MÄM-42-070, page 5-18a, and AFM-TR-MÄM-42-103, page 5-18b.
- d Mark AFM page 5-18 as superseded.
- e Incorporate Temporary Revision TR-MÄM-42-111/a into the AFM.
- f MSB 42-005 becomes obsolete with compliance to MSB 42-006/1 or later.

Action 3:

- a Remove AFM-TR-MÄM-42-070, page 5-18a, and AFM-TR-MÄM-42-103, page 5-18b.
- b Mark AFM page 5-18 as superseded.
- c Incorporate Temporary Revision TR-MÄM-42-111/a into the AFM.
- d MSB 42-005 becomes obsolete with compliance to MSB 42-006/1 or later.

## **I.9 Mass (Weight) and CG**

The change in mass and CG is negligible.

## **II PLANNING INFORMATION**

### **II.1 Material & Availability**

2 x D60-1127-10-51 Rev. "a" or later issue.  
Temporary Revision TR-MÄM-42-111/a is attached to this Service Bulletin.  
D60-1120-20-00SB is attached to this Service Bulletin.

### **II.2 Special Tools**

None

### **II.3 Credit**

Material (Safety Walk D60-1127-10-51 Rev. "a" or later issue)  
1 man hour of work

### **II.4 Reference Documents**

DA42 Series Airplane Maintenance Manual, Doc. No. 7.02.01, always latest revision.  
TR-MÄM-42-111/a

## **III REMARKS**

1. All measures must be carried out by the manufacturer, a certified repair aircraft station or a certified aircraft mechanic
2. Accomplishment of the measures must be confirmed in the log book.
3. In case of any doubt, contact Diamond Aircraft Industries.

8 7 6 5 4 3 2 1

F  
E  
D  
C  
B  
A

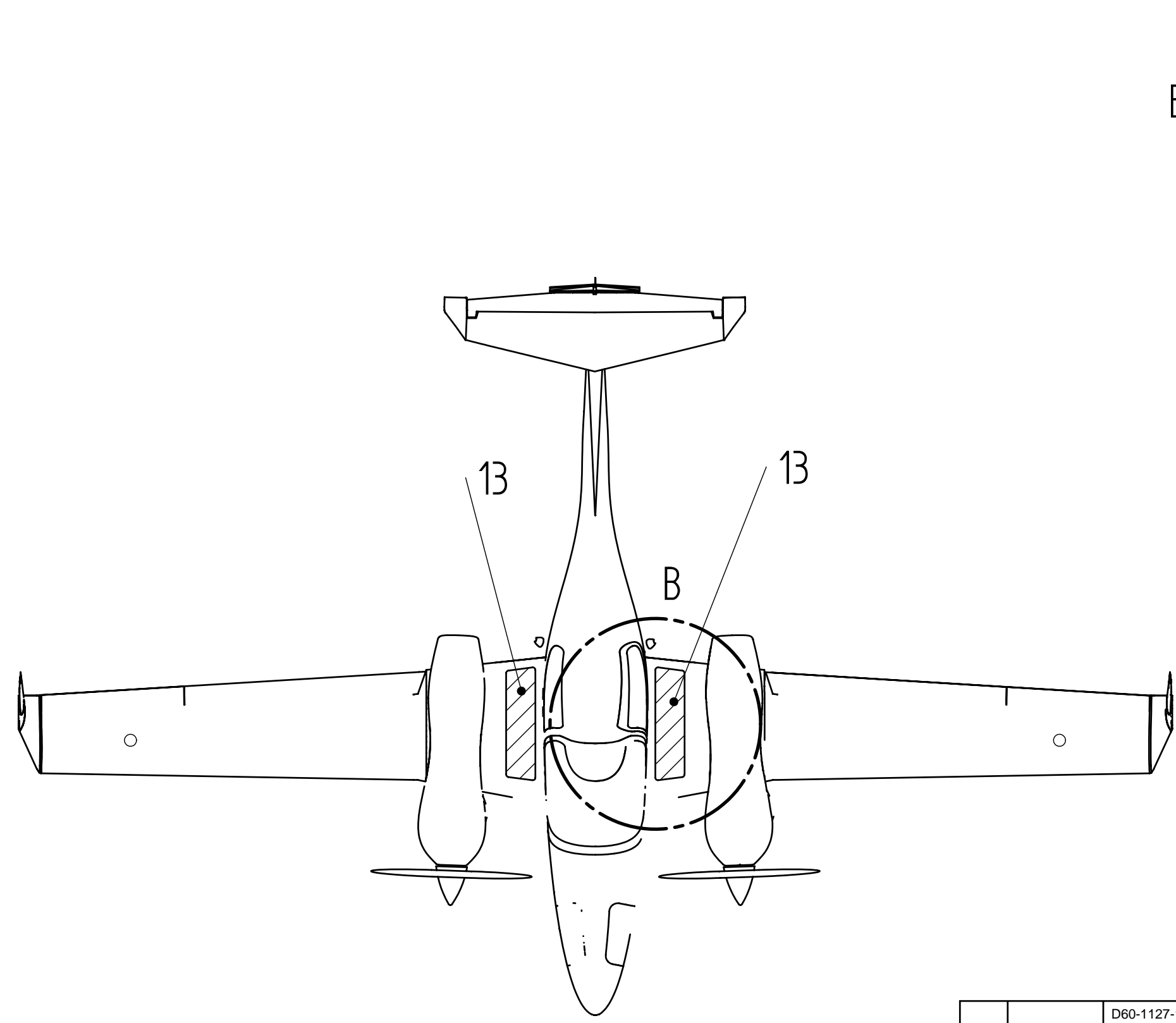

EINZELHEIT B

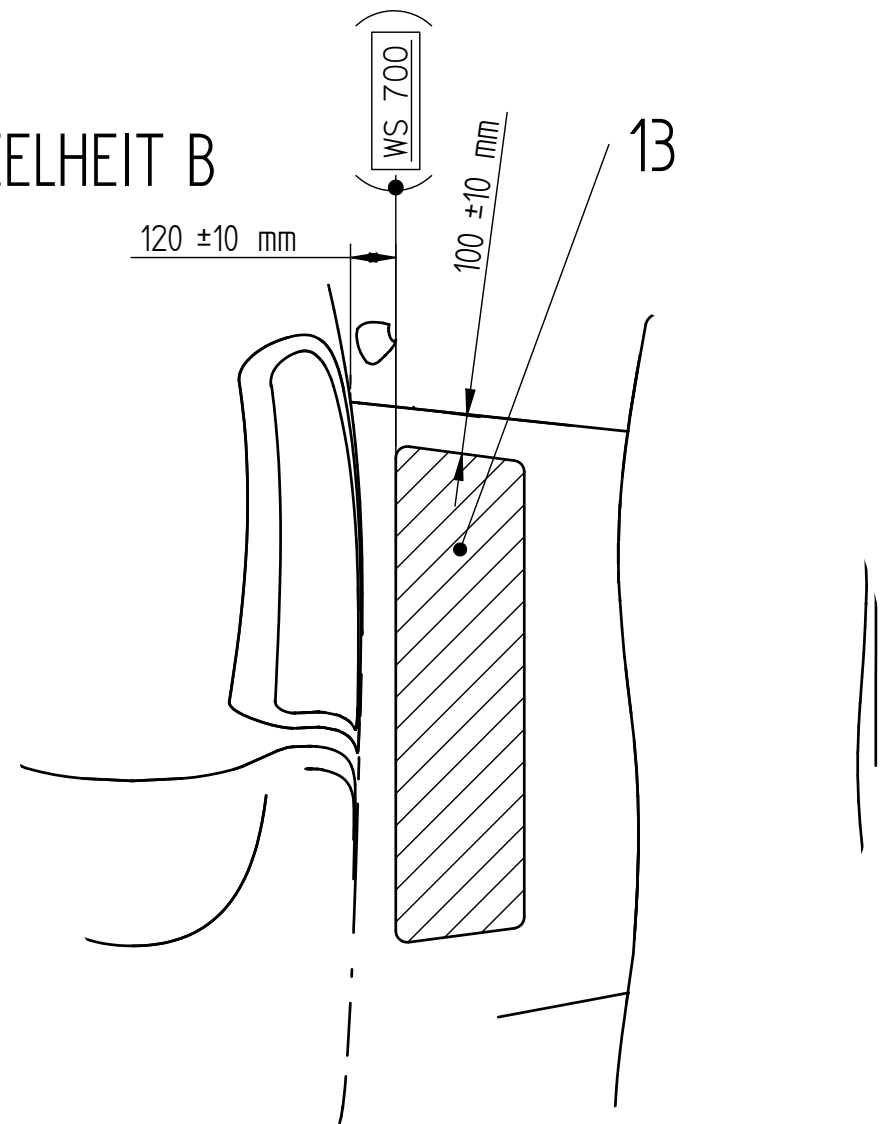

DIESE UNTERLAGE IST UNSER EIGENTUM UND DAFÜR OHNE UNSERE AUSDRÜCKLICHE GENEHMIGUNG WEDER Vervielfältigt NOCH DRITTEN PERSONEN ÜBERLASSEN WERDEN. ÜBERTRETUNGEN UNTERLEGEN DER VERFOLGUNG NACH DEN URHABERRECHTEN.  
 DIAMOND AIRCRAFT INDUSTRIES GmbH

13	2 x	D60-1127-10-51 Rev "a" or later Issue	Safety Walk		
Pos.	Stk.	Teile Nr.:	Benennung	Orientierung/Abmessung	Lieferant/Bemerkung
Freigabe :		Geprüft :		Freimaßtoleranz : ISO 2768 mittel	Maßstab :
Datum		Name			
		Nächster Zusammenbau :		Benennung : <b>Safety Walk Installierung</b>	
				Name : safety walk installation	
		DA42 Twin Star		Zeichnungs Nr.:	
"-"		MÄM 42-107a	10.10.05	Kremnitzer	D60-1120-20-00SB
Rev.	Änderung	Datum	Name	Gespeichert unter : D60-1120-20-00SB.dft	
					Blatt 1 von 1