



ÚŘAD PRO CIVILNÍ LETECTVÍ  
ČESKÁ REPUBLIKA  
**Sekce technická**  
letišťe Ruzyně, 160 08 Praha 6  
tel: 233320922, fax: 220562270

## PŘÍKAZ K ZACHOVÁNÍ LETOVÉ ZPŮSOBILOSTI

**Číslo: 2005-16-05**

Datum účinnosti: 26. srpna 2005

**Robinson Helicopter Company**  
vrtulník model R-22

---

Tento PZZ je vydáván pro výrobek transferovaný pod působnost EASA

Na základě rozhodnutí EASA je následující Příkaz k zachování letové způsobilosti závazný pro všechny výrobky provozované v EU na které se daný PZZ vztahuje.

Provedení PZZ, který se vztahuje podle typu a výrobního čísla na výrobek je pro provozovatele/vlastníka letadla zapsaného do leteckého rejstříku závazné. Neprovedením PZZ ve stanoveném termínu dojde ke ztrátě letové způsobilosti výrobku.

---

*Poznámky:*

- Provedení tohoto PZZ musí být zapsáno do provozní dokumentace letadla.
- Případné dotazy týkající se tohoto PZZ adresujte na ÚCL sekce technická.
- Pokud to vyžaduje povaha tohoto PZZ, musí být zpracován do příslušné části dokumentace pro obsluhu, údržbu a opravy letadla.

[Federal Register: August 11, 2005 (Volume 70, Number 154)]  
[Rules and Regulations]  
[Page 46743-46747]  
From the Federal Register Online via GPO Access [wais.access.gpo.gov]  
[DOCID:fr11au05-1]

---

## **DEPARTMENT OF TRANSPORTATION**

### **Federal Aviation Administration**

#### **14 CFR Part 39**

**[Docket No. FAA-2005-22026; Directorate Identifier 2005-SW-05-AD; Amendment 39-14210; AD 2005-16-05]**

**RIN 2120-AA64**

#### **Airworthiness Directives; Robinson Helicopter Company Model R-22 Series Helicopters**

**AGENCY:** Federal Aviation Administration, DOT.

**ACTION:** Final rule; request for comments.

---

**SUMMARY:** This amendment adopts a new airworthiness directive (AD) for the specified Robinson Helicopter Company (Robinson) Model R-22 series helicopters that have been modified in accordance with Supplemental Type Certificate (STC) No. SR09189RC. This action requires inspecting the left-hand door and right-hand door for a crack in the door assembly integral frame, and replacing the door assembly if a crack is found. This AD also requires inspecting each door assembly to determine if the weather seal set is airworthy and installed properly, inspecting each door hinge for the proper installation of a cotter pin, and thereafter, at intervals not to exceed 100 hours time-in-service (TIS), inspecting each door assembly integral frame for a crack. This amendment is prompted by one accident and one incident involving Robinson Model R-22 series helicopters. The actions specified in this AD are intended to prevent separation of a door window or door assembly from the helicopter, which could damage the tail rotor during flight and result in loss of control of the helicopter.

**DATES:** Effective August 26, 2005.

The incorporation by reference of certain publications listed in the regulations is approved by the Director of the Federal Register as of August 26, 2005.

Comments for inclusion in the Rules Docket must be received on or before October 11, 2005.

**ADDRESSES:** Use one of the following addresses to submit comments on this AD:

- DOT Docket Web site: Go to <http://dms.dot.gov> and follow the instructions for sending your comments electronically;
- Government-wide rulemaking Web site: Go to <http://www.regulations.gov> and follow the instructions for sending your comments electronically;
- Mail: Docket Management Facility; U.S. Department of Transportation, 400 Seventh Street, SW., Nassif Building, Room PL-401, Washington, DC 20590;
- Fax: (202) 493-2251; or

- Hand Delivery: Room PL-401 on the plaza level of the Nassif Building, 400 Seventh Street, SW., Washington, DC, between 9 a.m. and 5 p.m., Monday through Friday, except Federal holidays.

You may get the service information identified in this AD from Tech-Tool Plastics, Inc., 7800 Skyline Park Drive, Fort Worth, Texas 76108; telephone: (817) 246-4694; fax: (817) 246-7402; e-mail: [info@tech-tool.com](mailto:info@tech-tool.com).

## Examining the Docket

You may examine the docket that contains the AD, any comments, and other information on the Internet at <http://dms.dot.gov>, or in person at the Docket Management System (DMS) Docket Offices between 9 a.m. and 5 p.m., Monday through Friday, except Federal holidays. The Docket Office (telephone (800) 647-5227) is located on the plaza level of the Department of Transportation Nassif Building at the street address stated in the ADDRESSES section. Comments will be available in the AD docket shortly after the DMS receives them.

**FOR FURTHER INFORMATION CONTACT:** Marc Belhumeur, Aviation Safety Engineer, FAA, Rotorcraft Directorate, Rotorcraft Certification Office, Fort Worth, Texas 76193-0170, telephone (817) 222-5177, fax (817) 222-5783.

**SUPPLEMENTARY INFORMATION:** This amendment adopts a new AD for Robinson Model R-22 series helicopters that have been modified with door assemblies manufactured by Tech-Tool Plastics, Inc., in accordance with STC No. SR09189RC. This action requires:

- Within 30 days, inspecting each door assembly integral frame for a crack, and before further flight, replacing the left-hand door assembly, part number (P/N) R-22-101-51 or P/N R-22-101-53, or right-hand door assembly, P/N R-22-101-52 or P/N R-22-101-54, if a crack is found;
- Within 30 days, if crack is not found on a door assembly, inspecting the door assembly weather seal set to determine if it is airworthy and installed properly, and if it is not, before further flight, reinstalling or replacing the weather seal set with weather seal set, P/N 74418x14L and P/N 74814x12BL, or with any other appropriate airworthy weather seal set;
- Within 30 days, if a crack is not found on a door assembly, inspecting to determine that a cotter pin, P/N MS24665-136, is installed properly in each of the two hinges on the door assembly, and if it is not, before further flight, properly installing the cotter pin;
- Thereafter, at intervals not to exceed 100 hours (TIS), inspecting each door assembly integral frame for a crack and replacing the door assembly if a crack is found; and,
- Within 30 days after discovering a crack, reporting that information as well as the helicopter model to the FAA. You may submit your report via mail, Fax, or telephone to the FAA, ATTN: ASW-170 (Marc Belhumeur), 2601 Meacham Blvd., Fort Worth, Texas 76137; telephone: (817) 222-5177; Fax: (817) 222-5783.

This amendment is prompted by an accident on November 27, 2004, involving a Robinson Model R-22 Beta helicopter, which resulted in two fatalities. This amendment is also prompted by one incident involving a Robinson Model R-22 series helicopter, which was reported to Tech-Tool Plastics, Inc., the door assembly manufacturer, on September 20, 2004. A preliminary investigation of the helicopter involved in the accident indicated that the doors separated from the helicopter at some undetermined time and that the separation may have been partially due to the door hinge cotter pins not being installed properly. In the incident, an operator reported that the window in the pilot door had separated from the helicopter during flight at an altitude of 4,500 feet. Subsequent investigation revealed cracking across the composite door assembly integral frame stiffener bead, just beneath the lower hinge on the forward edge of the door, and at the upper and lower door cam lock on the trailing edge of the door. Further investigation revealed that the door weather seal set was not the weather seal set supplied by the door assembly manufacturer. Additionally, the two nylon adjustment screws, which are required to relieve excessive force on the door hinges, were broken or missing. Finally, the door may not have been trimmed to the cabin door opening as stated in the

manufacturer's door assembly installation drawings. The actions specified in this AD are intended to prevent separation of a door window or door assembly from the helicopter, which could damage the tail rotor during flight and result in loss of control of the helicopter.

We have reviewed Tech-Tool Plastics, Inc. Installation Instructions, TTP-1R, Revision A, dated November 21, 1997, which is part of STC SR09189RC authorizing installation of door assemblies on these affected helicopters. We have also reviewed Tech-Tool Plastics, Inc. Service Bulletin No. TTP2005-01, Revision A, dated February 1, 2005 (SB), which describes procedures for a one-time visual inspection for cracks and proper installation of the door assemblies and before the first flight of each day recurring visual checks for cracks. The SB also includes weather seal set and cotter pin installation instructions that were inadvertently omitted from the Installation Instructions of TTP-1R, Revision A, dated November 21 1997. Cracks in a helicopter door or improper installation create an unsafe condition.

This unsafe condition is likely to exist or develop on other helicopters of the same supplemental type design. Therefore, this AD is being issued to prevent separation of a door window or door assembly from the helicopter, which could damage the tail rotor during flight and result in loss of control of the helicopter. This AD requires inspecting the left-hand door and right-hand door for a crack in the door assembly integral frame, and replacing the door assembly if a crack is found. This AD also requires inspecting each door assembly to determine if the weather seal set is airworthy and installed properly, inspecting each door hinge for the proper installation of a cotter pin, and inspecting each door assembly integral frame for a crack at intervals not to exceed 100 hours TIS. Also, reporting the results of the inspections to the FAA is required if a crack is found. Accomplish the required actions in accordance with the specified portions of the service information described previously. The short compliance time involved is required because the previously described critical unsafe condition can adversely affect the structural integrity and controllability of the helicopter. Since the one-time inspections of each door assembly frame, cotter pins, and weather seal set are required within 30 days, and because each 100-hour TIS interval for inspecting each door assembly frame for cracking may occur within 30 calendar days for those helicopters being used for training or other high usage missions, this AD must be issued immediately.

Since a situation exists that requires the immediate adoption of this regulation, it is found that notice and opportunity for prior public comment hereon are impracticable, and that good cause exists for making this amendment effective in less than 30 days.

We estimate that this AD will affect 200 helicopters of U.S. registry, and the actions will take approximately:

- .1 work hour to inspect for cracking in each door assembly integral frame;
- .1 work hour to inspect the weather seal set, and both cotter pins in each door assembly; and
- .5 work hour to install each door assembly.

The average labor rate is \$65 per work hour. Required parts will cost approximately \$4,464 per helicopter if replacing each door assembly and reinstalling and trimming each door is required. Based on these figures, we estimate the total cost impact of the AD on U.S. operators to be \$1,857,400, assuming 366 inspections for cracking in each door assembly integral frame are accomplished, and that both door assemblies on all Robinson Model R-22 series helicopters are replaced.

### **Comments Invited**

This AD is a final rule that involves requirements that affect flight safety and was not preceded by notice and an opportunity for public comment; however, we invite you to submit any written data, views, or arguments regarding this AD. Send your comments to an address listed under ADDRESSES. Include "Docket No. FAA-2005-14210; Directorate Identifier 2005-SW-05-AD" at the beginning of your comments. We specifically invite comments on the overall regulatory, economic, environmental, and energy aspects of the AD. We will consider all comments received by the closing date and may amend the AD in light of those comments.

We will post all comments we receive, without change, to <http://dms.dot.gov>, including any personal information you provide. We will also post a report summarizing each substantive verbal contact with FAA personnel concerning this AD. Using the search function of our docket web site, you can find and read the comments to any of our dockets, including the name of the individual who sent the comment. You may review the DOT's complete Privacy Act Statement in the Federal Register published on April 11, 2000 (65 FR 19477-78), or you may visit <http://dms.dot.gov>.

## **Regulatory Findings**

We have determined that this AD will not have federalism implications under Executive Order 13132. This AD will not have a substantial direct effect on the States, on the relationship between the national Government and the States, or on the distribution of power and responsibilities among the various levels of government.

For the reasons discussed above, I certify that the regulation:

1. Is not a "significant regulatory action" under Executive Order 12866;
2. Is not a "significant rule" under the DOT Regulatory Policies and Procedures (44 FR 11034, February 26, 1979); and
3. Will not have a significant economic impact, positive or negative, on a substantial number of small entities under the criteria of the Regulatory Flexibility Act.

We prepared an economic evaluation of the estimated costs to comply with this AD. See the DMS to examine the economic evaluation.

## **Authority for This Rulemaking**

Title 49 of the United States Code specifies the FAA's authority to issue rules on aviation safety. Subtitle I, section 106, describes the authority of the FAA Administrator. Subtitle VII, Aviation Programs, describes in more detail the scope of the Agency's authority.

We are issuing this rulemaking under the authority described in subtitle VII, part A, subpart III, section 44701, "General requirements." Under that section, Congress charges the FAA with promoting safe flight of civil aircraft in air commerce by prescribing regulations for practices, methods, and procedures the Administrator finds necessary for safety in air commerce. This regulation is within the scope of that authority because it addresses an unsafe condition that is likely to exist or develop on products identified in this rulemaking action.

## **List of Subjects in 14 CFR Part 39**

Air transportation, Aircraft, Aviation safety, Incorporation by reference, Safety.

## **Adoption of the Amendment**

Accordingly, pursuant to the authority delegated to me by the Administrator, the Federal Aviation Administration amends part 39 of the Federal Aviation Regulations (14 CFR part 39) as follows:

### **PART 39—AIRWORTHINESS DIRECTIVES**

1. The authority citation for part 39 continues to read as follows:

Authority: 49 U.S.C. 106(g), 40113, 44701.

#### **§ 39.13 [Amended]**

2. Section 39.13 is amended by adding a new airworthiness directive to read as follows:

# AIRWORTHINESS DIRECTIVE



Aircraft Certification Service  
Washington, DC

U.S. Department  
of Transportation  
**Federal Aviation  
Administration**

*We post ADs on the internet at "www.faa.gov"*

---

The following Airworthiness Directive issued by the Federal Aviation Administration in accordance with the provisions of Title 14 of the Code of Federal Regulations (14 CFR) part 39, applies to an aircraft model of which our records indicate you may be the registered owner. Airworthiness Directives affect aviation safety and are regulations which require immediate attention. You are cautioned that no person may operate an aircraft to which an Airworthiness Directive applies, except in accordance with the requirements of the Airworthiness Directive (reference 14 CFR part 39, subpart 39.3).

**2005-16-05 Robinson Helicopter Company:** Amendment 39-14210. Docket No. FAA-2005-22026; Directorate Identifier 2005-SW-05-AD.

## **Applicability**

Model R-22 series helicopters, modified with a door assembly manufactured by Tech-Tool Plastics, Inc., in accordance with STC No. SR09189RC, certificated in any category.

## **Compliance**

Required as indicated, unless accomplished previously.

To prevent separation of a door window or door assembly from the helicopter, which could damage the tail rotor during flight and result in loss of control of the helicopter, accomplish the following:

(a) Within 30 days, inspect the left-hand and right-hand door assemblies as follows:

(1) Visually inspect each pilot and copilot door assembly integral frame for a crack in the locations depicted in Figure 1 of this AD. If a crack is found, before further flight, replace the cracked door assembly, part number (P/N) R-22-101-51 or P/N R-22-101-53 (left-hand door assembly), or P/N R-22-101-52 or P/N R-22-101-54 (right-hand door assembly), with an airworthy door assembly. If you use door assembly, P/N R-22-101-51 or P/N R-22-101-53 (left-hand door assembly), or P/N R-22-101-52 or P/N R-22-101-54 (right-hand door assembly) as the replacement, then install it in accordance with Tech-Tool Plastics, Inc. Installation Instructions TTP-1R, Revision A, dated November 21, 1997, and with the sections titled "Door Weather Seal Installation" and "Cotter Pin Installation" in Tech-Tool Plastics, Inc. Service Bulletin No. TTP2005-01, Revision A, dated February 1, 2005 (SB).

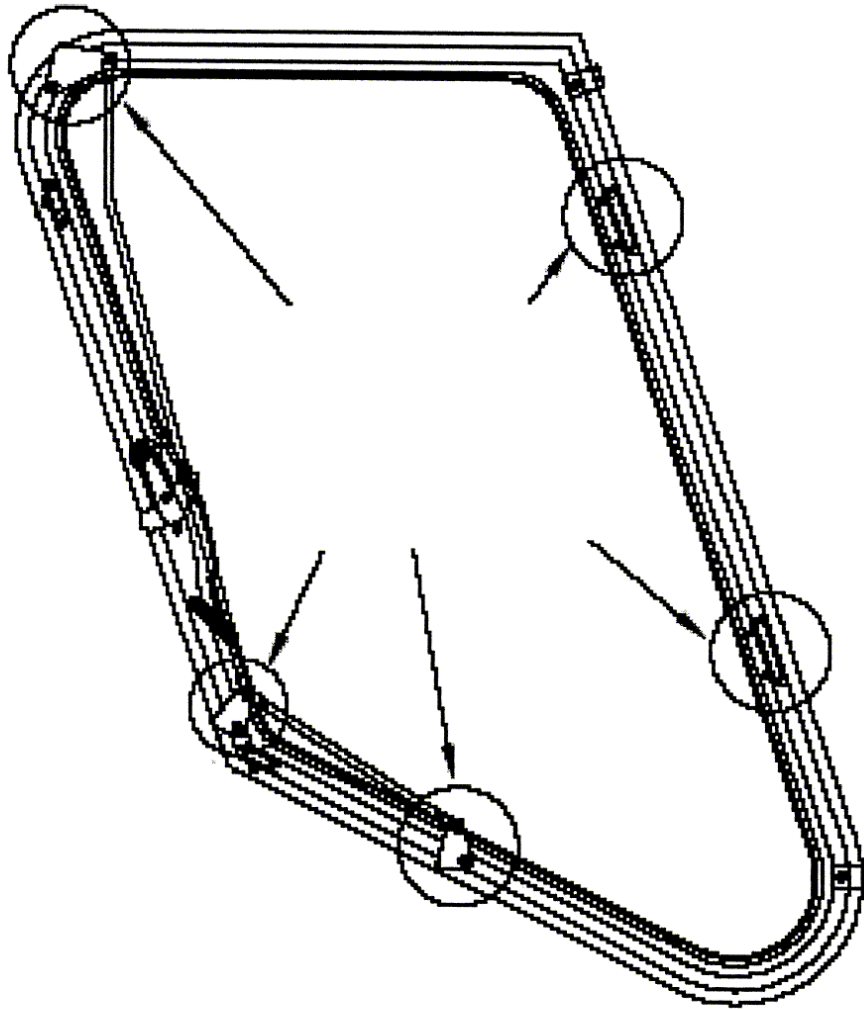

**Door Assembly (left-hand shown) View Looking Outboard**

**Figure 1**

(2) If no crack is found in any door assembly integral frame, do the following:

(i) Visually inspect the weather seal set in each door assembly to determine if it is airworthy and installed properly. If it is not airworthy, before further flight, replace it with either the weather seal set, P/N 74418X14L and P/N 74814X12BL, supplied by Tech-Tool Plastics, Inc., in accordance with the "Door Weather Seal Installation" section of the SB, or replace it with any other airworthy door weather seal set in accordance with the applicable FAA-approved installation instructions. If an airworthy weather seal set, P/N 74418X14L and P/N 74814X12BL, is not installed properly, before further flight, reinstall it in accordance with the "Door Weather Seal Installation" section of the SB. If the improperly installed weather seal set is not the weather seal set supplied by Tech-Tool Plastics, Inc., before further flight, reinstall it in accordance with the applicable FAA-approved installation instructions.

(ii) Visually inspect each door hinge on each door assembly to determine if the cotter pins, P/N MS24665-136, are installed in accordance with the "Cotter Pin Installation" section of the SB. If a cotter pin is not installed in accordance with the "Cotter Pin Installation" section of the SB, before further flight, install the cotter pins in accordance with the "Cotter Pin Installation" section of the SB.

**Note:** The installation of nylon adjustment screws and the trimming of door assembly edges are important maintenance actions that may reduce the strength of a door assembly if not done properly.

(b) After accomplishing the inspections in paragraphs (a) through (a)(2)(ii) of this AD, at intervals not to exceed 100 hours time-in-service, visually inspect each pilot and copilot door assembly integral frame for a crack in the locations depicted in Figure 1 of this AD.

(c) If a crack is found, before further flight, replace the cracked door assembly, P/N R-22-101-51 or P/N R-22-101-53 (left-hand door assembly), or P/N R-22-101-52 or P/N R-22-101-54 (right-hand door assembly), with an airworthy door assembly. If the replacement door assembly is P/N R-22-101-51 or P/N R-22-101-53 (left-hand door assembly), or P/N R-22-101-52 or P/N R-22-101-54 (right-hand door assembly), then install it in accordance with Tech-Tool Plastics, Inc. Installation Instructions TTP-1R, Revision A, dated November 21, 1997, and "Door Weather Seal Installation" and "Cotter Pin Installation" sections of the SB.

(d) If any of the inspections required by this AD reveal a crack in any door assembly frame, report the following information to the FAA within 30 days after discovering the crack: a description of the crack and the specific helicopter model involved. You may submit your report via mail, Fax, or telephone to the FAA, ATTN: ASW-170 (Marc Belhumeur), 2601 Meacham Blvd., Fort Worth, Texas 76137, telephone (817) 222-5177, fax (817) 222-5783. Information collection requirements contained in this AD have been approved by the Office of Management and Budget (OMB) under the provisions of the Paperwork Reduction Act of 1980 (44 U.S.C. 3501 et seq.) and have been assigned OMB Control Number 2120-0056.

(e) To request a different method of compliance or a different compliance time for this AD, follow the procedures in 14 CFR 39.19. Contact the Rotorcraft Certification Office, Rotorcraft Directorate, FAA, for information about previously approved alternative methods of compliance.

(f) The inspections, repairs and replacements, if necessary, shall be done in accordance with the specified portions of Tech-Tool Plastics, Inc. Installation Instructions TTP-1R, Revision A, dated November 21, 1997, which provides door assembly installation instructions, and the specified portions of Tech-Tool Plastics, Inc. Service Bulletin No. TTP2005-01, Revision A, dated February 1, 2005, which describes door weather seal and cotter pin installation procedures and door assembly inspection procedures. The Director of the Federal Register approved this incorporation by reference in accordance with 5 U.S.C. 552(a) and 1 CFR part 51. Copies may be obtained from Tech-Tool Plastics, Inc., 7800 Skyline Park Drive, Fort Worth, Texas, 76108; telephone: (817) 246-4694; fax: (817) 246-7402; E-mail: *info@tech-tool.com*.

(g) This amendment becomes effective on August 26, 2005.

Issued in Fort Worth, Texas, on July 29, 2005.

S. Frances Cox,  
Acting Manager, Rotorcraft Directorate, Aircraft Certification Service.  
[FR Doc. 05-15580 Filed 8-10-05; 8:45 am]  
BILLING CODE 4910-13-P