



ÚŘAD PRO CIVILNÍ LETECTVÍ
ČESKÁ REPUBLIKA

letišťe Ruzyně, 160 08 Praha 6
tel: 02/324086, fax: 02/364112

PŘÍKAZ K ZACHOVÁNÍ LETOVÉ ZPŮSOBILOSTI

Číslo: CAA-AD-1-025/98

Toto PZZ nahrazuje CAA-AD-3-65/97

Datum vydání: 6. dubna 1998

Louis L'Hotellier S.A.
Rychlospojky řízení

KLUZÁK - RYCHLOSPOJKY ŘÍZENÍ - ÚPRAVA

Týká se: několika typů rychlospojek řízení vyrobených společnostmi LOUIS L'HOTELLIER namontovaných na kluzácích podle seznamu, ale nejen na těchto.

Výrobce: verze kluzáku:
Alexander Schleicher : ASW15B, ASW19B, ASW20L

Rolladen Schneider : LS1- všech verzí.

Schempp-Hirth : Std Cirrus, Cirrus VTC, Nimbus 2, Nimbus 2B,L-295 Janus.

Slingsby : T-59 Kestrel

Důvod vydání:

Opakované problémy s kulovými spojkami řízení, které způsobily několik nehod kluzáků.

Datum účinnosti: 09.04.1998

Provést v termínech:

Proveďte v následující roční prohlídce kluzáku, ne později než k datu 15.5.1998.

Postup provedených prací:

Dle části „Action“ LBA AD číslo 1993-001/3 a 1994-001/2 (které jsou přílohou tohoto PZZ).

Poznámky:

- Provedení tohoto PZZ musí být zapsáno do deníku kluzáku.
- Případné dotazy týkající se tohoto PZZ adresujte na ÚCL technický inspektorát - Ing. V. Příhoda
- Pokud to vyžaduje povaha tohoto PZZ musí být zapracován do příslušné části dokumentace pro obsluhu, údržbu a opravy kluzáku.
- Tento PZZ byl vypracován na základě LBA AD číslo 1993-001/3 a 1994-001/2

Ing. Pavel MATOUŠEK
Ředitel technického inspektorátu
Úřad pro civilní letectví

**Airworthiness
Directive
1994-001/2**

Luftfahrt-Bundesamt
Airworthiness Directive Section
Lilienthalplatz 6
38108 Braunschweig
Federal Republic of Germany

L'Hotellier ball and socket connectors

Effective Date: April 09,1998

Affected:

Kind of aeronautical product: Aircraft
Manufacturer: L'Hotellier
Type: L'Hotellier ball and socket connectors
Models affected: ball and socket connectors type 45 -ratchet-
Serial numbers affected: all
German Type Certificate No.: none

Subject:

L'Hotellier ball and socket connectors with locking cams (type .45; ratchet), if installed in sailplanes, powered sailplanes and aeroplanes

Reason:

Evaluations of reported incidents involving L'Hotellier ball and socket connectors with locking cams have prompted the LBA to have these connectors also incorporated into the investigations as to the operational safety of L'Hotellier ball and socket connectors.

The results are similar to those obtained with the ball and socket connectors with lock plates.

As has been demonstrated in the tests, even normal operating conditions are sufficient under unfavourable circumstances to surmount the static friction, i.e. even the locking cams may open. The a.m. airworthiness deficiency may result in inadvertent disconnect of the L'Hotellier ball and socket connectors and thus to considerable operational malfunctions.

Controllability of the aircraft may be affected or even lost so that the defect may lead to an accident.

As a result of this, the ball and socket connectors are to be secured with safety pins, Uerlings sleeves or in accordance with the instructions by the aircraft manufacturers.

For well-founded reasons, especially the Uerlings type sleeves are to be inspected for the absence of cracks and sufficient self locking ability and, if necessary, are to be replaced.

Action:

The Luftfahrt-Bundesamt emphasizes the fact that all pilots have to familiarize themselves with the particularities of L'Hotellier connectors, especially with the different locking systems and their handling.

Also the ball and socket connectors with locking cams type 45 must be secured.

1.

Safety pins (e.g. L'H 140-31 made by Hotellier) have to be retrofitted. If the locking cams have not already been fitted with holes (□ 1.3 mm) these holes are to be drilled within the framework of this AD (see attachment section II).

The use of a safety pin can be waived if the L'Hotellier ball and socket connector is already equipped with an approved locking system (e.g. Uerlings sleeve and others) or if such a system is to be installed.

Uerlings sleeves or other sleeves functioning according to this principle (specification number SE-OOI/78) can only be installed for straight joints and transmissions, but cannot be used for 90° joints.

Inspection of Uerlings type sleeves

Inspection of the locking sleeves for the absence of cracks and sufficient locking force (self-locking ability), replacement of the sleeves, if necessary.

Installation information:

The sleeves have to be slid axially onto the L'Hotellier ball and socket connectors, they may by no means be clipped radially onto the L'Hotellier ball and socket connector. Radial clipping (excessive opening of the sleeve) may lead to cracks or ruptures due to overstraining so that the sleeve cannot function properly any more.

Annual inspection:

The sleeves shall be inspected at least once a year for the absence of cracks and sufficient locking force (self-locking ability). In the original specification for the Uerlings sleeves a biannual replacement interval is assumed. Deviations from this provision are stated in the technical information by the manufacturers.

2.

Flight Manual

a) Section "Rigging"

The recommendation : "The lock plate of L'Hotellier ball and socket connectors should be secured"... given in several Flight Manuals in the a.m. or in a similar form is to be deleted and to be replaced by the following sentence:

"The L'Hotellier ball and socket connector must be secured."

b) If older Flight Manuals do not contain information about L'Hotellier ball and socket connectors, section I (see attachment) is to be included in the Flight Manual under the Section "Rigging", if the L'Hotellier connector is or is to be locked by means of a safety pin. If necessary, the entry is to be included on a new page.

c) If Uerlings type sleeves are used, additional locking systems for L'Hotellier connectors, section III of the attachment is to be included in the Flight Manual.

These entries in the Flight Manual may be hand-written or inserted as a copy indicating the AD no.1994-001/2 in the Flight Manual.

The amendment is to be entered in the list of effective pages indicating the AD no.1994-001/2.

Information:

Type-related technical information already published by the manufacturer or by the product support organisation for L'Hotellier ball and socket connectors become part of this AD.

Working instruction for action no.1

Action no.1, drilling a hole, is described in section II of the attachment.

The safety pins are available from:

- L'Hotellier: safety pin reference no. L'H 140-31
- manufacturers or product support organisations for the types of sailplanes, powered sailplanes or aeroplanes concerned
- others: safety pin \square 1.2 mm, Ford reference no.1473 931 (worldwide)

Compliance:

Locking of L'Hotellier connectors:

- on sailplanes and powered sailplanes not later than April 30th, 1994.
- on aeroplanes not later than May 15th, 1998.

Inspection of the Uerlings type sleeves on all aircraft:

With the next annual inspection but not later than May 15th,1998, and thereafter at least once a year.

Technical publication of the manufacturer:

-none-

Accomplishment and log book entry:

Action to be accomplished by an approved maintenance organisation and to be checked and entered in the log book by a licensed inspector.

Note:

This AD supersedes the AD-No.1994-001 dated February 03,1994.

Holders of affected aircraft registered in Germany have to observe the following:

As a result of the a.m. deficiencies, the airworthiness of the aircraft is affected to such an extent that after the expiry of the a.m. dates the aircraft may be operated only after proper accomplishment of the prescribed actions. In the interest of aviation safety outweighing the interest of the receiver in a postponement of the prescribed actions, the immediate compliance with this AD is to be directed.

Instructions about Available Legal Remedies:

An appeal to this notice may be raised within a period of one month following notification. Appeals must be submitted in writing or registered at the Luftfahrt-Bundesamt, Lilienthalplatz 6, 38108 Braunschweig.

Attachment to Airworthiness Directive No. 1994-001/2
L'Hotellier ball and socket connector, type 45 - ratchet -
Attachment page 1 of 2

Section I

L'Hotellier ball and socket connectors

Prior to installation everyone should familiarize with the functioning of Hotellier ball and socket connectors.

The socket is to be slid completely over the ball on the rod with the locking cam pulled back. During locking the locking cam moves back slightly so that in a correct connection the hole on the averted edge of the locking cam becomes visible.

The safety pin is to be inserted in this hole thus securing the ball and socket connector.

Attention:

By loading the connection full engagement of the ball is to be verified!

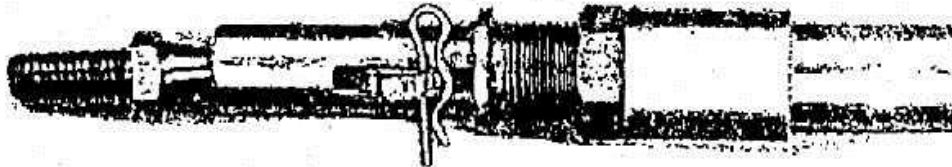

Warning:

Unsecured ball and socket connectors may open automatically in flight.

Section II

Working instruction for drilling the hole:

For fitting the hole proceed as follows:

Drill the hole \varnothing 1.3 mm with the ball correctly inserted so that one edge of the hole is level with the main body of the connector and on the other side at least 1.5 mm of material is left (see also the following sketch).

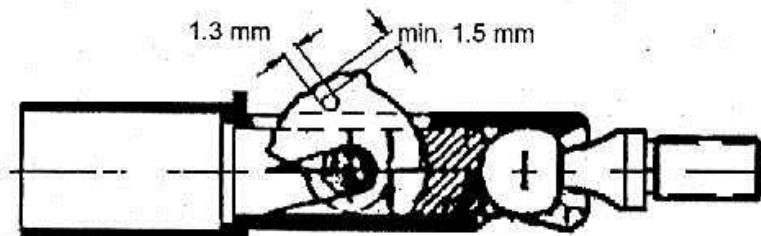

Warning:

When working on the connector, please see to it that no borings get in between the ball and the socket.

Attachment to Airworthiness Directive no. 1994-001/2
L'Hotellier ball and socket connector, type 45 - ratchet -
Attachment page 2 of 2

Section III

Installation instruction for Uerlings type sleeves by means of the example of the locking cam

(for the ratchet type connector, the installation is to be accomplished analogously)

For installation, the sleeves have to be slid axially onto the L'Hotellier ball and socket connectors.

They may by no means be clipped radially onto the L'Hotellier ball and socket connector. Radial clipping (excessive opening of the sleeve) may lead to cracks or ruptures due to oversteering so that the sleeve cannot function properly any more.

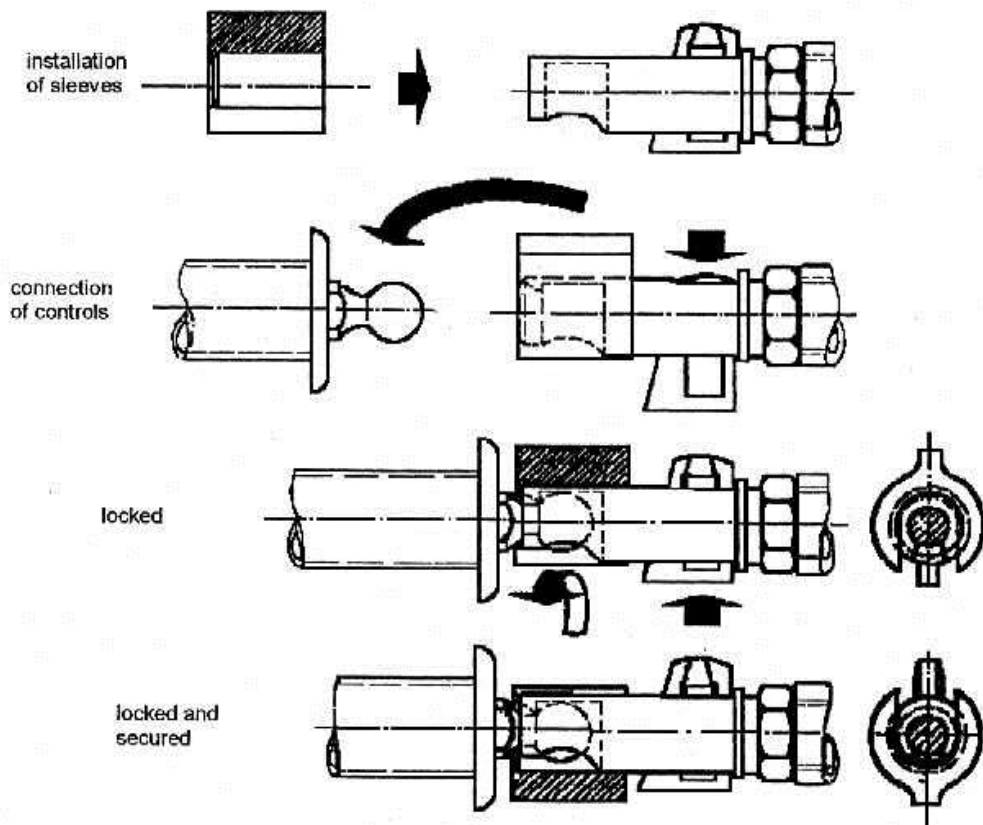

**Airworthiness
Directive
1994-001/3**

Luftfahrt-Bundesamt
Airworthiness Directive Section
Lilienthalplatz 6
38108 Braunschweig
Federal Republic of Germany

L'Hotellier ball and socket connectors

Effective Date: April 09,1998

Affected:

Kind of aeronautical product: Aircraft
Manufacturer: L'Hotellier
Type: L'Hotellier ball and socket connectors with lock plates
Models affected: ball and socket connectors with lock plates
Serial numbers affected: all
German Type Certificate No.: none

Subject:

L'Hotellier ball and socket connectors with lock plates if installed in sailplanes, powered sailplanes and aeroplanes

Reason:

Reported incidents involving L'Hotellier ball and socket connectors have prompted the LBA to have investigations made as to the operational safety of L'Hotellier ball and socket connectors. The results have shown that the friction surfaces of the lock plates will be run in and smoothed after a relatively small number of operations. As has been demonstrated in the tests, in this case even normal operating conditions are sufficient under unfavourable circumstances to surmount the static friction (i.e. the lock plates open).

The a.m. airworthiness deficiency may result in inadvertent disconnect of the L'Hotellier ball and socket connectors and thus to considerable operational malfunctions.

Controllability of the aircraft may be affected or even lost so that the defect may lead to an accident.

The reason for the issue of the second edition in April 1994 was the revision of the L'Hotellier Instruction for Maintenance by which the roundness tolerance of the ball was increased from max. 0.05 mm to 0.1 mm.

The ball and socket connectors are to be secured by means of safety pins, Uerlings sleeves or Uerlings type sleeves.

This AD has been issued as a result of several occurrences with Uerlings type sleeves. For well-founded reasons, especially these sleeves are to be inspected for absence of cracks and sufficient self locking ability and, if necessary, are to be replaced.

Action:

The Luftfahrt-Bundesamt emphasizes the fact that all pilots have to familiarize themselves with the particularities of L'Hotellier connectors, especially with the different locking systems and their handling.

The ball and socket connectors with lock plates are to be secured. For this purpose, the following actions are to be accomplished:

1.

Safety pins (e.g. L'H 140-31 made by Hotellier), have to be retrofitted, if not yet installed. In certain cases, it may become necessary to rebore the hole in the lock plate, which is provided for visual inspection, to \square 1.2 mm so that the safety pin can be inserted (see attachment section I).

The use of a safety pin can be waived if the L'Hotellier ball and socket connector is already equipped with an approved locking system (e.g. Uerlings type sleeve, LS locking sleeve, Schempp-Hirth spring or Wedekind locking system) or if such a system is to be installed:

LBA approved locking systems: see attachment section II.

Uerlings type sleeves (specification number SE-OOI/78) as well as LS locking sleeves can only be used-for straight joints and transmissions, but cannot be used for 90° joints.

Inspection of Uerlings Type Sleeves

Inspection of these sleeves for the absence of cracks and sufficient locking force (self-locking ability), replacement of the sleeves, if necessary (see attachment part III).

Installation information:

The sleeves have to be slid axially onto the L'Hotellier ball and socket connector, they may by no means be clipped radially onto the L'Hotellier ball and socket connector. Radial clipping (excessive opening of the sleeve) may lead to cracks or ruptures due to overstraining so that the sleeve cannot function properly any more.

Annual inspection of sleeves:

The sleeves shall be inspected at least once a year for the absence of cracks and sufficient locking force (self-locking ability). In the original specification for the Uerlings sleeves a biannual replacement interval is assumed. Deviations from this provision are stated in the technical information by the manufacturers.

2. Flight Manual

a) Section "Rigging"

The recommendation : "The lock plate of L'Hotellier ball and socket connectors should be secured"... given in several Flight Manuals in the a.m. or in a similar form is to be deleted and to be replaced by the following sentence:

"The L'Hotellier ball and socket connector must be secured."

b) If older Flight Manuals do not contain information about L'Hotellier ball and socket connectors, section IV (see

attachment) is to be included in the Flight Manual under the Section "Rigging", if the L'Hotellier connector is or is

to be secured by means of a safety pin. If necessary, the entry is to be included on a new page:

c) If Uerlings type sleeves are used as additional locking systems for L'Hotellier connectors, section III of the attachment is to be included in the Flight Manual.

These entries in the Flight Manual may be hand-written or inserted as a copy indicating the AD-No.1993-001/3 in the Flight Manual.

The amendment is to be entered in the list of effective pages indicating the AD-No.1993-001/3.

3.

Maintenance Manual

The enclosed Instructions for Maintenance (L'Hotellier, issue E 03/94) become herewith part of the operating instructions

and are to be included in the aircraft Maintenance Manual - as far as this has not been done already by the manufacturers of the sailplanes, powered sailplanes, and aeroplanes concerned.

4.

All L'Hotellier ball and socket connectors are to be inspected in accordance with the above Instructions for Maintenance. Connectors exceeding the allowable tolerances are to be replaced.

Note:

Type-related technical information already published by the manufacturer or by the product support organisation for

L'Hotellier ball and socket connectors become part of this AD.

The safety pins are available from:

- L'Hotellier safety pin, reference no. L'H 140-31

- safety pin □ 1.2 mm, Ford reference no.1473 931 (worldwide)

- manufacturers or product support organisations for the sailplane, powered sailplane or aeroplane types concerned

Compliance:

Locking of L'Hotellier connectors:

- on sailplanes and powered sailplanes not later than April 30th, 1994.
- on aeroplanes not later than May 15th, 1998.

Inspection of the Uerlings type sleeves on all aircraft:

With the next annual inspection but not later than May 15th,1998, and thereafter at least once a year.

Technical publication of the manufacturer:

-none-

Accomplishment and log book entry:

Action to be accomplished by an approved maintenance organisation and to be checked and entered in the log book by a licensed inspector.

Note:

This AD supersedes the AD-No.1993-001/2 dated April 20, 1994.

Holders of affected aircraft registered in Germany have to observe the following:

As a result of the a.m. deficiencies, the airworthiness of the aircraft is affected to such an extent that after the expiry of the a.m. dates the aircraft may be operated only after proper accomplishment of the prescribed actions. In the interest of aviation safety outweighing the interest of the receiver in a postponement of the prescribed actions, the immediate compliance with this AD is to be directed.

Instructions about Available Legal Remedies:

An appeal to this notice may be raised within a period of one month following notification. Appeals must be submitted in writing or registered at the Luftfahrt-Bundesamt, Lilienthalplatz 6, 38108 Braunschweig.

Attachment to Airworthiness Directive No. 1993-001/3
L'Hotellier ball and socket connector, lock plate

Attachment page 1 of 4

Section I

L'Hotellier ball and socket connectors with lock plate

If the connectors are not yet equipped with safety pins (e.g. l'H 140-31 made by Hotellier), these safety pins have to be retrofitted. In certain cases it may become necessary to rebores the hole in the lock plate, which is provided for visual inspection, to \varnothing 1.2 mm so that the safety pin can be inserted.

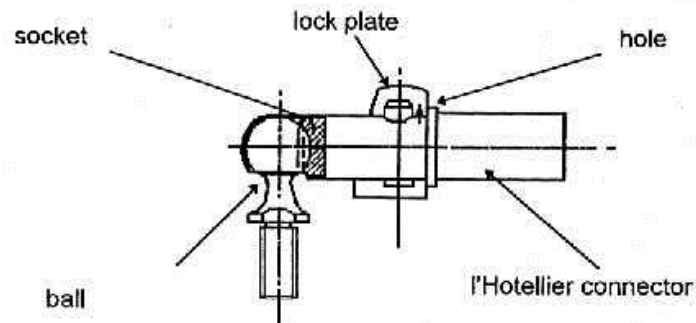

Warning!

Unsecured ball and socket connectors may open automatically in flight!

Attachment to Airworthiness Directive No. 1993-001/3
L'Hotellier ball and socket connector, lock plate

Attachment page 2 of 4

Section II

LBA-approved locking systems

The following systems to secure l'Hotellier ball and socket connectors are LBA-approved: Uerlings sleeves or Uerlings type sleeves (see section III), safety pin (figures 2 and 2a), LS-safety sleeve (figure 3), Schempp-Hirth spring (figure 4) und Wedekind locking system (figure 5).

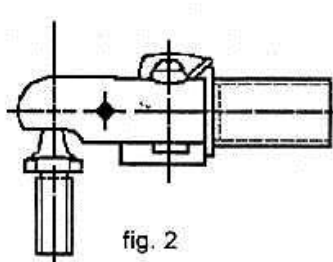

fig. 2

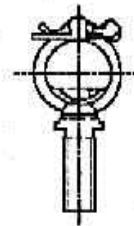

fig. 2a

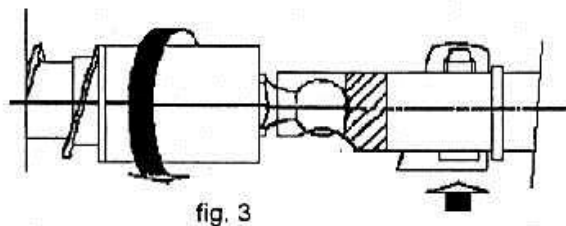

fig. 3

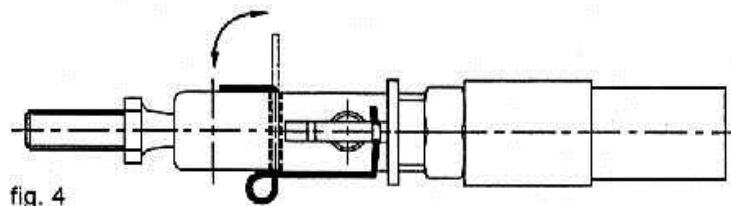

fig. 4

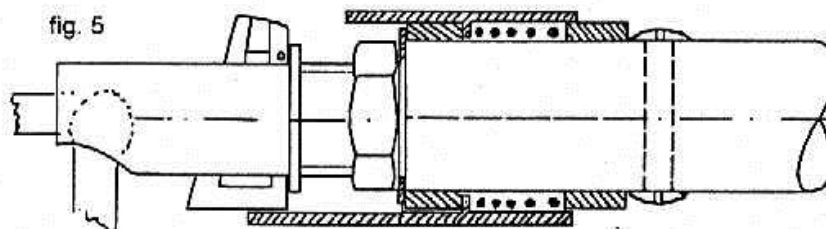

fig. 5

Attachment to Airworthiness Directive No. 1993-001/3
L'Hotellier ball and socket connector, lock plate

Attachment page 3 of 4

Section III

Installation instruction for Uerlings type sleeves

For installation, the sleeves have to be slid axially onto the l'Hotellier ball and socket connectors.

They may by no means be clipped radially onto the l'Hotellier ball and socket connector. Radial clipping (excessive opening of the sleeve) may lead to cracks or ruptures due to overstressing so that the sleeve cannot function properly any more.

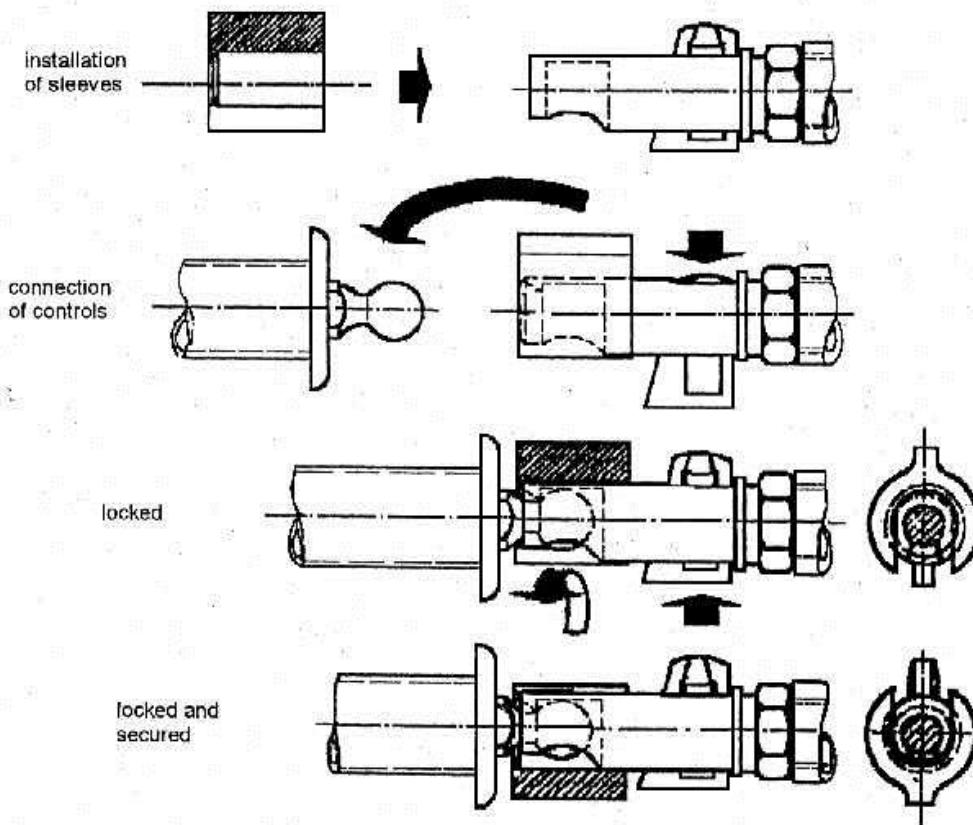

Attachment to Airworthiness Directive No. 1993-001/3
L'Hotellier ball and socket connector, lock plate

Attachment page 4 of 4

Section IV

L'Hotellier ball and socket connectors

Prior to the installation of ball and socket connectors, everyone has to familiarize himself with their functioning.

The socket is to be slid completely over the ball with the lock plate pressed down. During locking the lock plate moves back slightly so that in a correct connection the hole on the narrow edge of the lock plate becomes visible.

The safety pin is to be inserted in this hole thus securing the ball and socket connector.

Attention:

By loading the connection full engagement of the ball is to be verified!

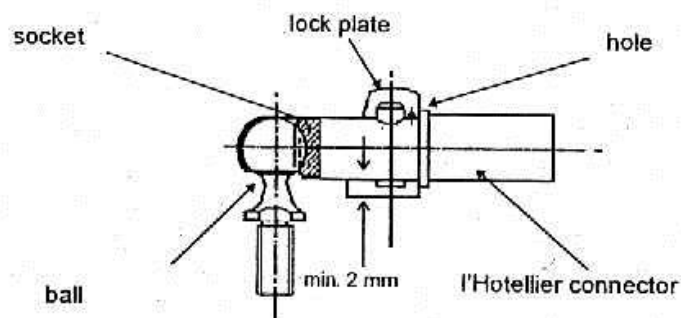

Warning!

Unsecured ball and socket connectors may open automatically in flight.